



Client _____ Quantity _____
 Project _____ Position _____

Master 650 lt cabinet

Model: A80/1BU

Cod: A14080600101

Technical data

Gross capacity:	573 lt
Temperature range:	-18°-22°C
Refrigerant unit:	Plug-In
Energetic class:	D
Energy efficiency index:	56,7
Annual consumption:	2093 kW/h annum
24h consumption:	5,734 kW/h/24h
Climate class:	5
Cooling gas:	R290
Defrost:	Hot gas
Valve:	Supplied standard with solenoid
Dimensions:	810×715×2085 mm
Packing dimensions:	905×830×2250 mm
Gross weight:	145 Kg
Voltage:	220-240 V - 50 Hz
Total rate:	1000 W
Absorbed Current:	4,6 A
Cooling capacity:	692 W*
*:	Evap. -30°C Cond. +55°C

Features

Standard equipment:	3 slides for GN2/1 shelves, 3 plastic coated GN2/1 shelves, lock with key, LED lighting
Control:	Electronic, display flush with the panel
Doors:	1 door, self-closing with a 105° stop, right hinged
Door gasket:	Magnetic, triple chamber and easily replaceable
Insulation:	75 mm thickness - CFC/HCFC free
Exterior/interior finishing:	Interno/esterno in acciaio inox AISI 304; schiena esterna, fondo e interno vano tecnico in acciaio galvanizzato/colaminato
Inner corners:	Rounded for easy cleaning and ensuring maximum hygiene
Handle:	Stainless steel AISI 304, 2 mm thick
Racks and slides:	Acciaio inox AISI 304
Feets:	Stainless steel AISI 304, adjustable h 100-150 mm

COSMO - wi-fi control

Cosmo is the innovative wi-fi technology that allows to connect all Coldline appliances in the kitchen and monitor them constantly from your smartphone. Connect Master cabinets to a Cosmo hub (MODI, VISION or LEVTRONIC) and from the app you can check the operating conditions of each machine in real time and receive any alerts in the event of power cuts or improper personnel interventions.



Technical draw

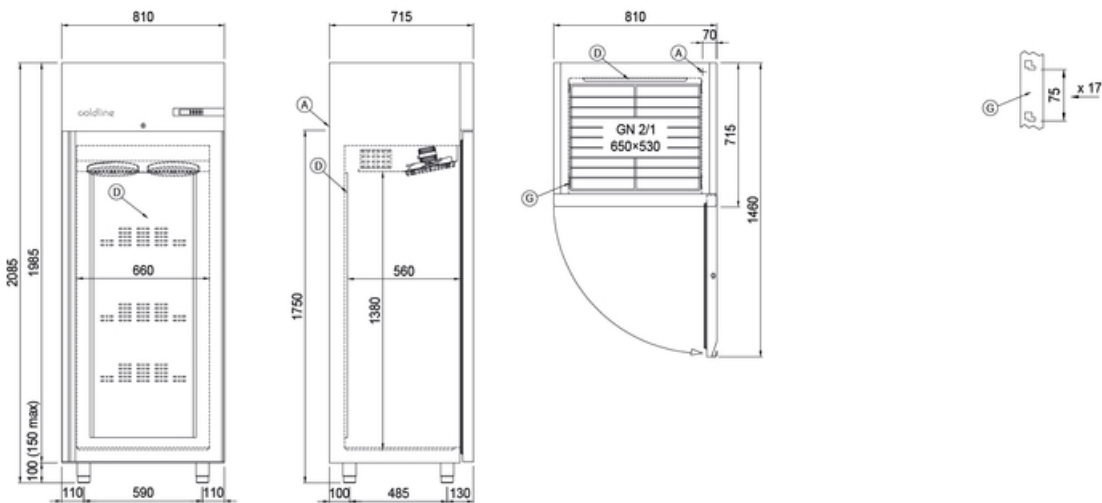

- A: Power supply cable outlet
- G: Racks pitch

- D: Airflow conveyor

In order to constantly offer the best possible products we reserve the right to make changes on technical specifications without incurring any obligation for equipment previously or subsequently sold.