



Client _____ Quantity _____
 Project _____ Position _____

Smart 700 cabinet

Model: A70/1BE

Cod: A12070600101

Technical data

Gross capacity:	601 lt
Temperature range:	-18°-22°C
Refrigerant unit:	Plug-In
Energetic class:	C
Energy efficiency index:	43,6
Annual consumption:	1609 kW/h annum
24h consumption:	4,408 kW/h/24h
Climate class:	5
Cooling gas:	R290
Defrost:	Hot gas
Valve:	Supplied standard with solenoid
Dimensions:	740×815×2085 mm
Packing dimensions:	835×930×2250 mm
Gross weight:	150 Kg
Voltage:	220-240 V - 50 Hz
Total rate:	810 W
Absorbed Current:	3,7 A
Cooling capacity:	453 W*
*:	Evap. -30°C Cond. +55°C

Features

Standard equipment:	3 slides for GN2/1 shelves, 3 plastic coated GN2/1 shelves, lock with key
Control:	Electronic, display flush with the panel
Doors:	1 door, self-closing with a 105° stop, right hinged
Door gasket:	Magnetic, triple chamber and easily replaceable
Insulation:	75 mm thickness - CFC/HCFC free
Exterior/interior finishing:	Exterior and interior AISI 304 stainless steel. Back, base and internal technical compartment in galvanized/ colaminated steel.
Inner corners:	Rounded for easy cleaning and ensuring maximum hygiene
Handle:	In PVC
Racks and slides:	Stainless steel AISI 304
Feets:	Stainless steel AISI 304, adjustable h 100-150 mm
Cosmo:	Ready for connection to Cosmo Hub

Accessories and variants

Power supply frequency 60Hz
 Other special voltage
 Half doors Smart
 Frame for fixed masonry plinth
 Kit für Öffnung der Tür mit Pedal
 4 Swivel and brake castors h 128 mm
 1 door LED lighting
 Stainless steel shelf GN2/1
 Plastic coated shelf GN2/1
 Pair of type C slides 605 mm
 Serial interface, RS485 cable
 Cosmo connection kit

COSMO - wi-fi control

Cosmo is the wi-fi technology that allow to connect and monitor all Coldline appliances. Connect Smart cabinets to a Cosmo hub (MODI, VISION or LEVTRONIC) and from the app you can check the operating conditions of each machine and receive alerts in case of abnormal functioning.

*The installation requires a kit for the replacement of the racks

Technical draw

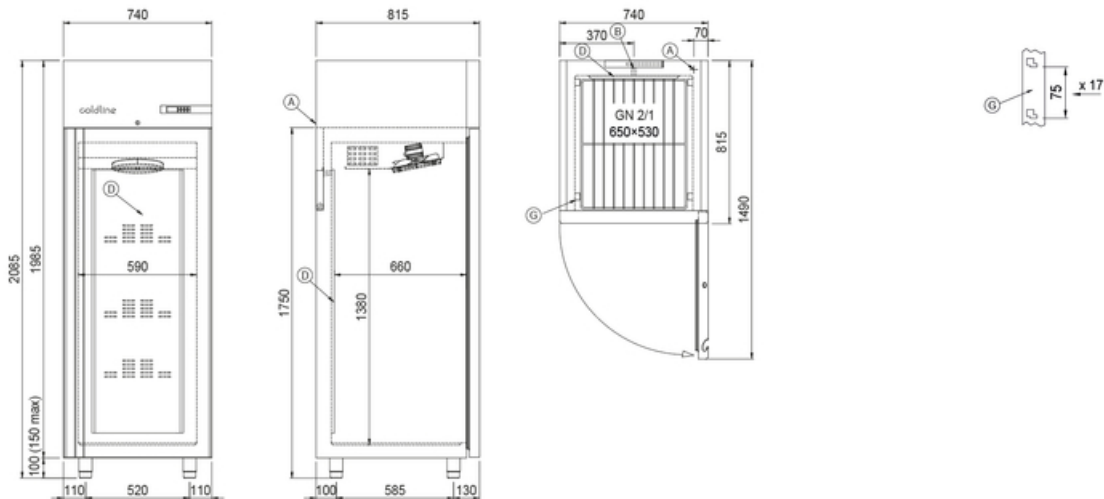

A: Power supply cable outlet

D: Airflow conveyor

G: Racks pitch